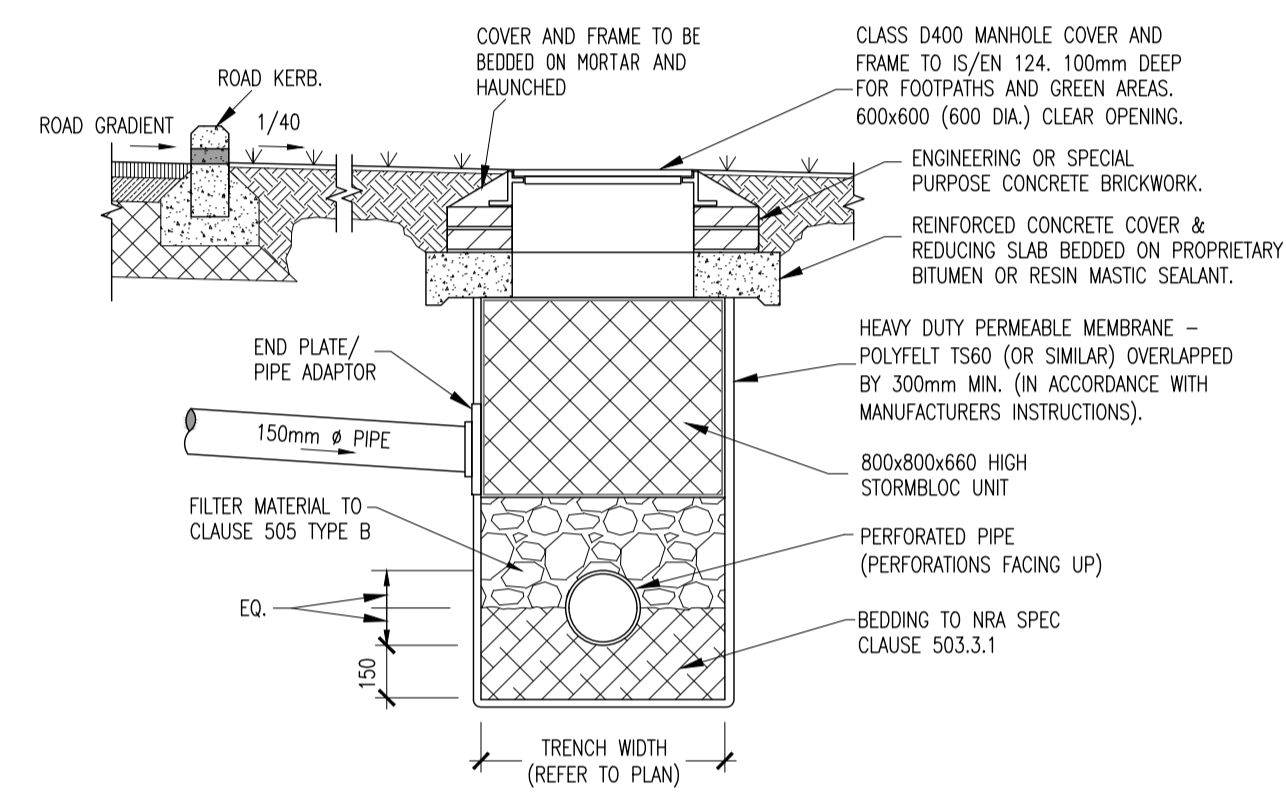
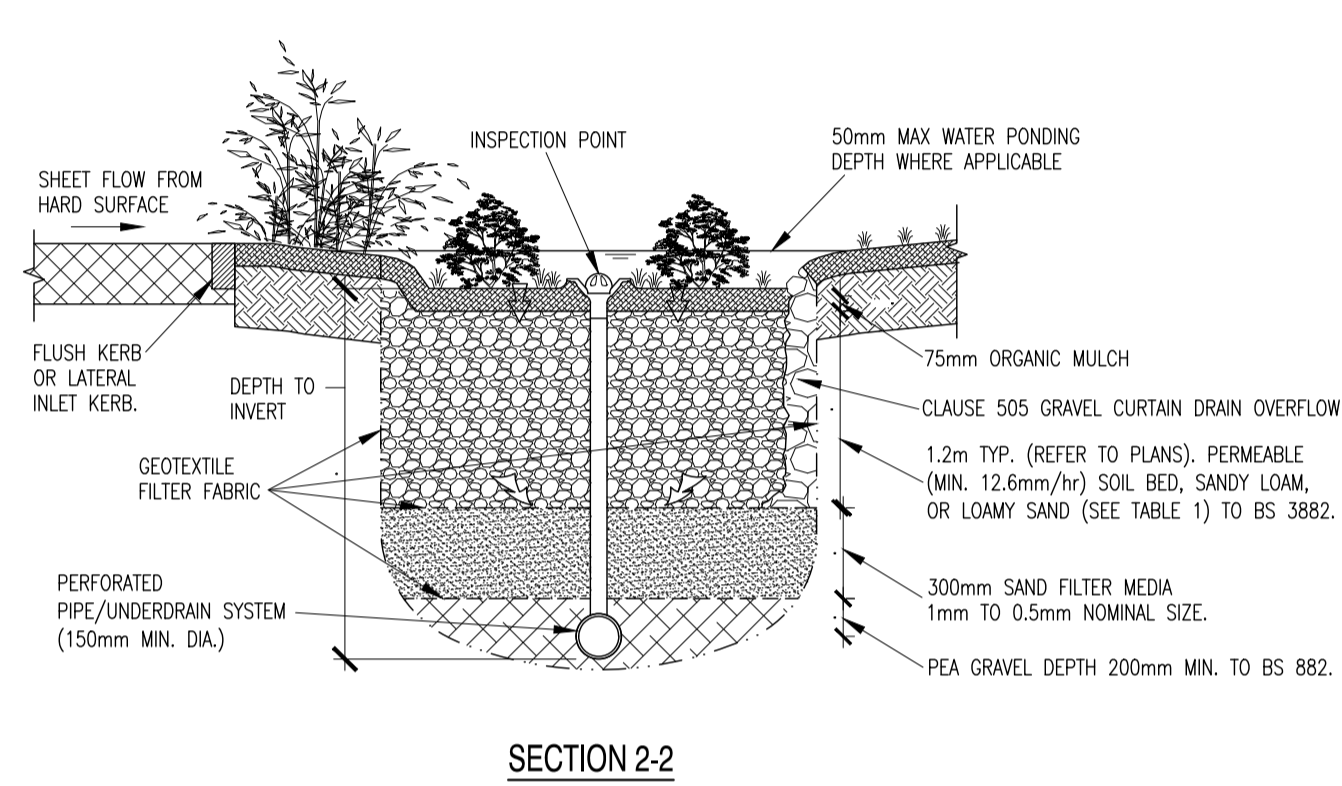
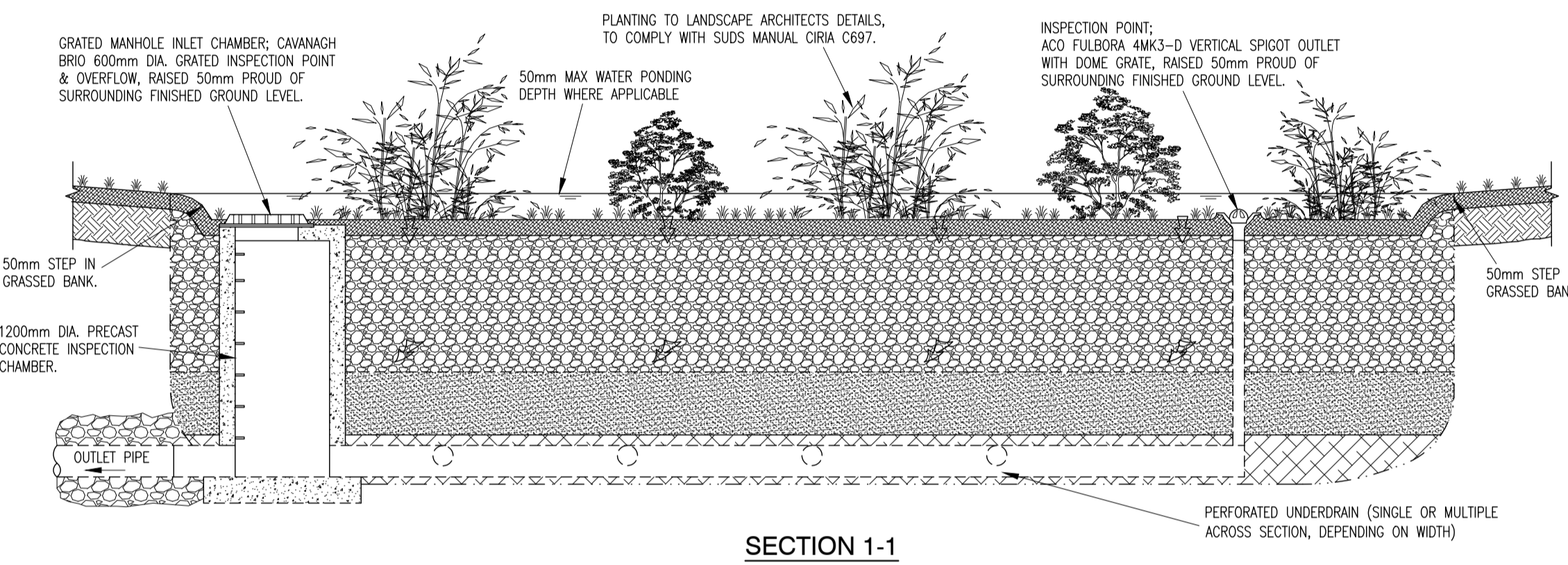
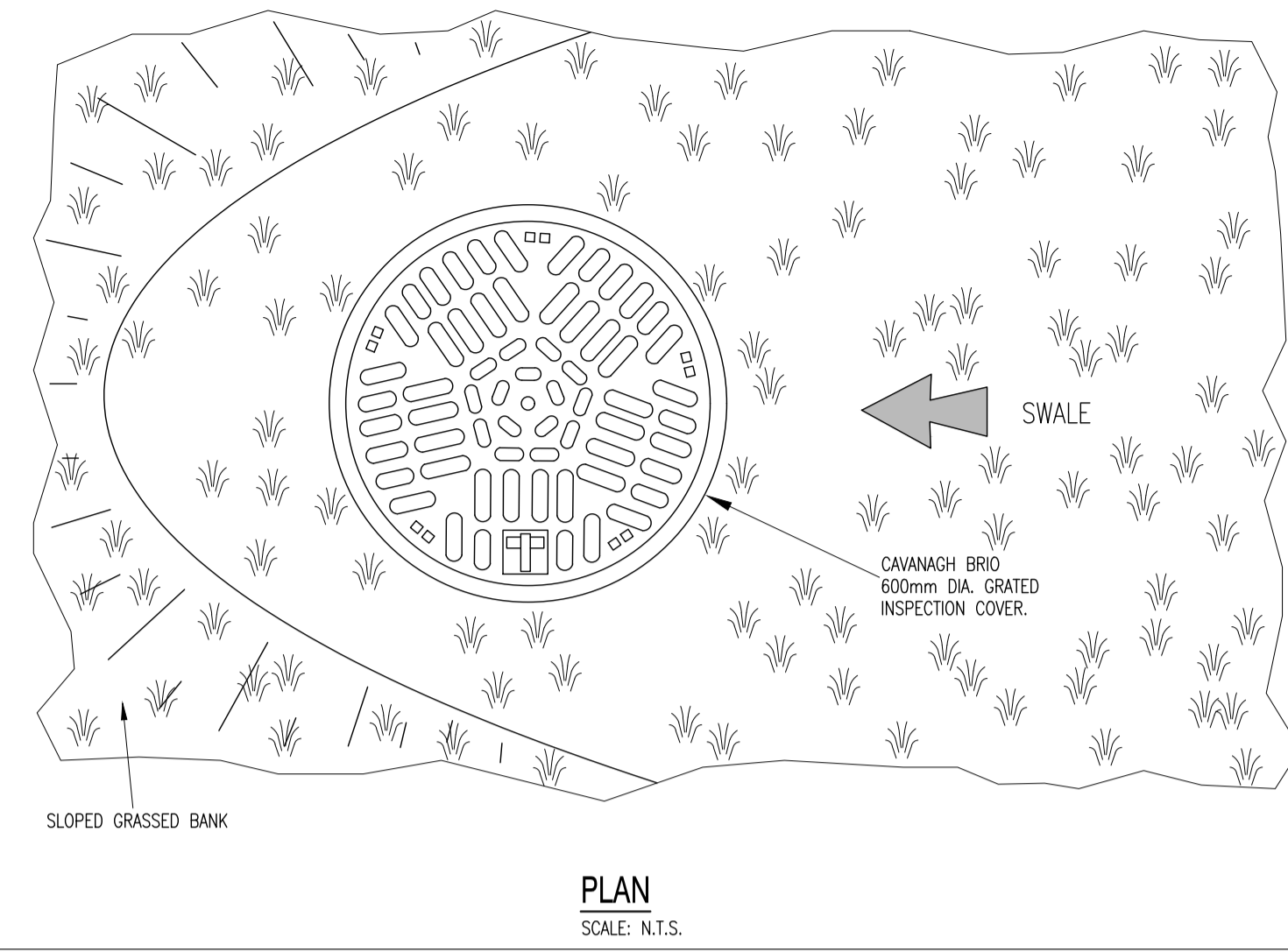
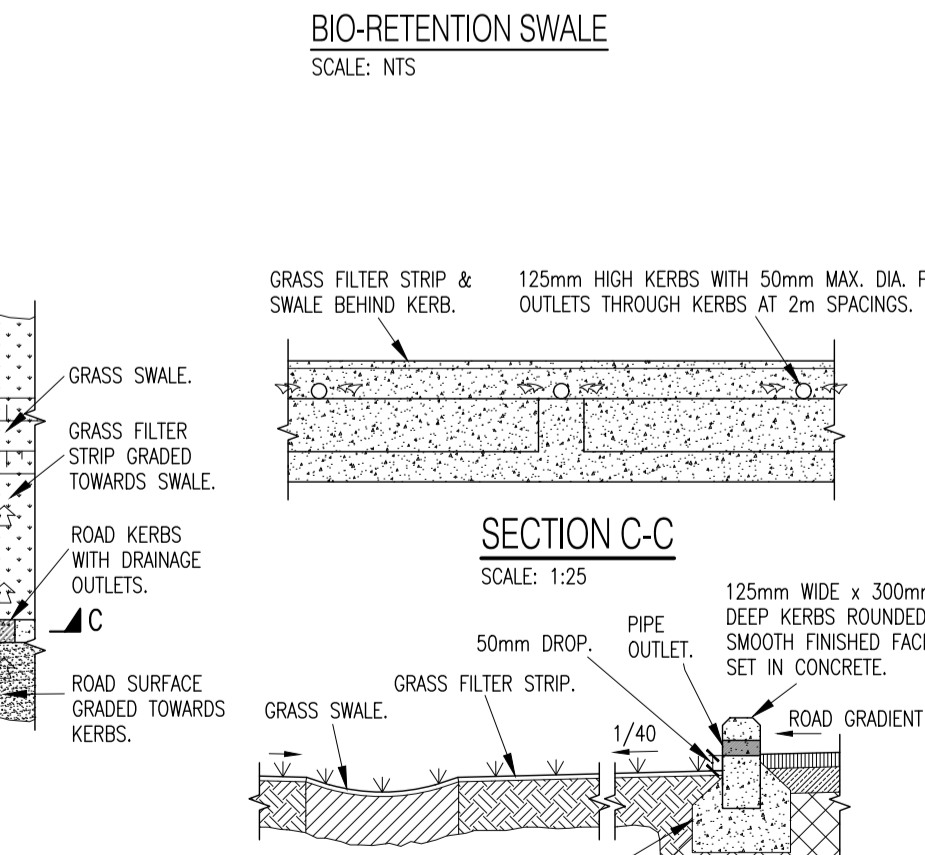
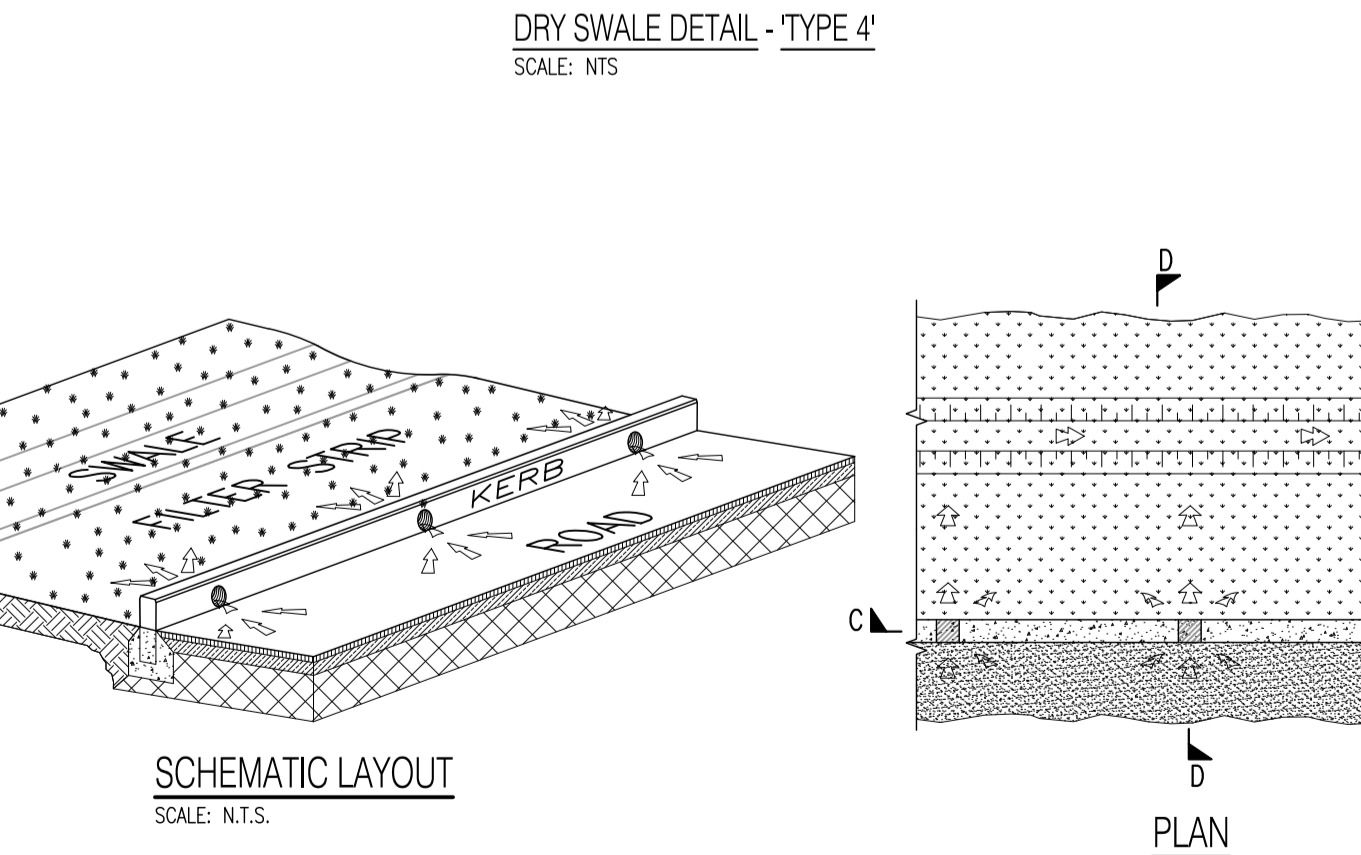
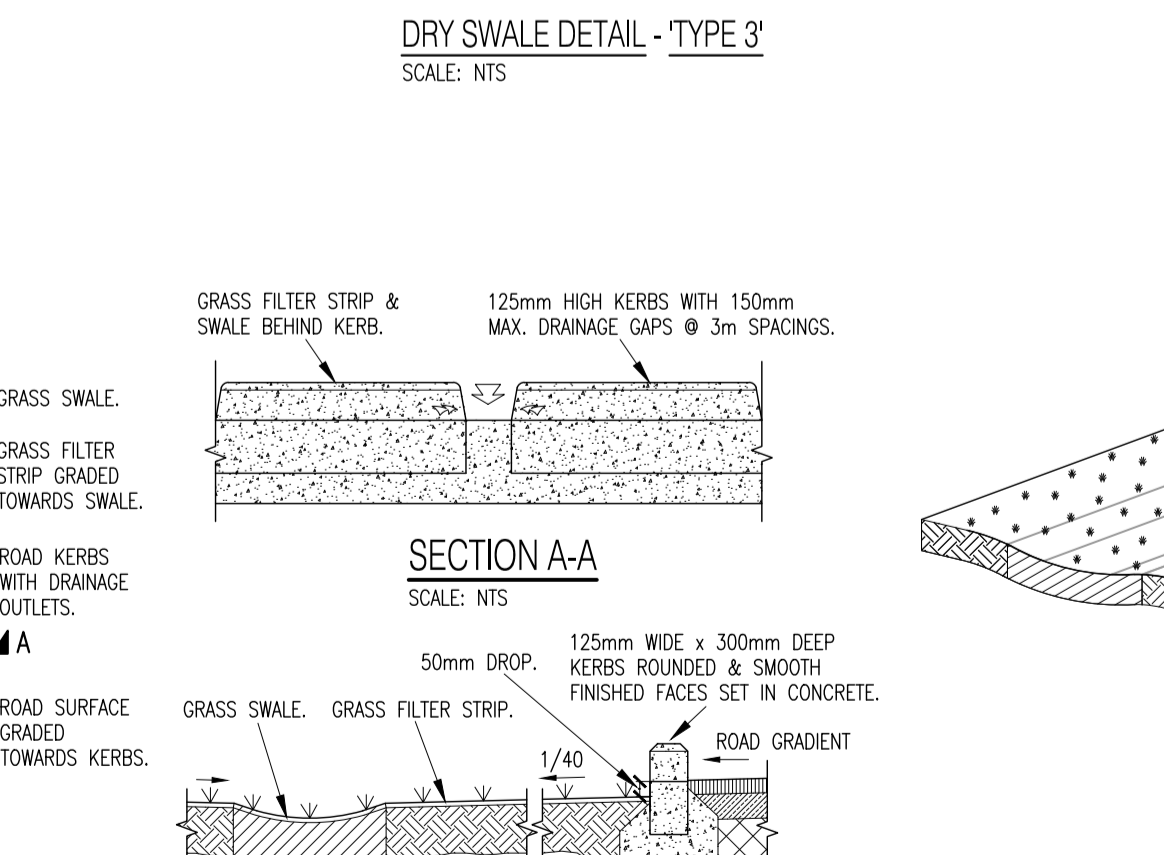
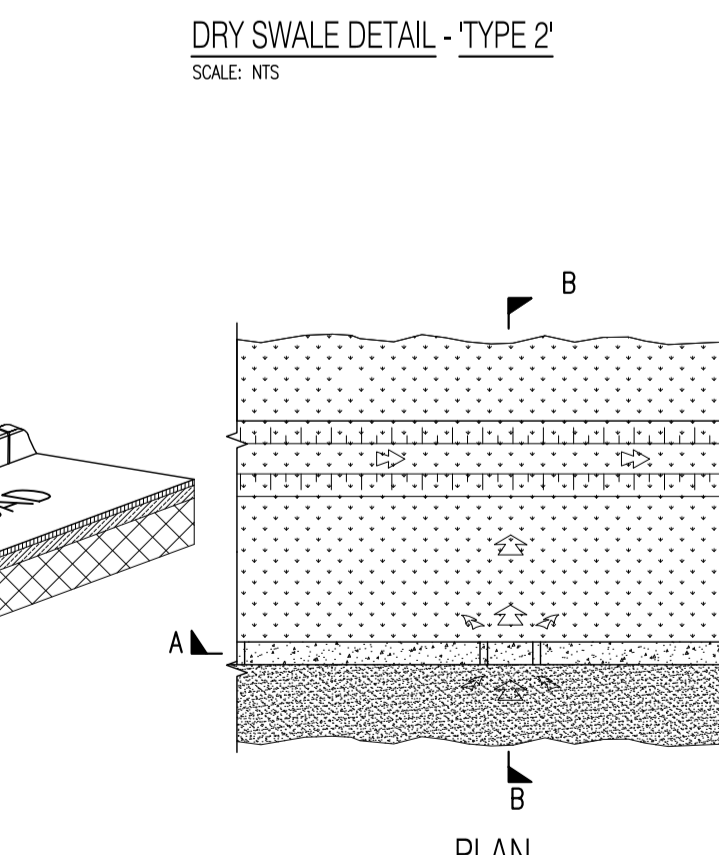
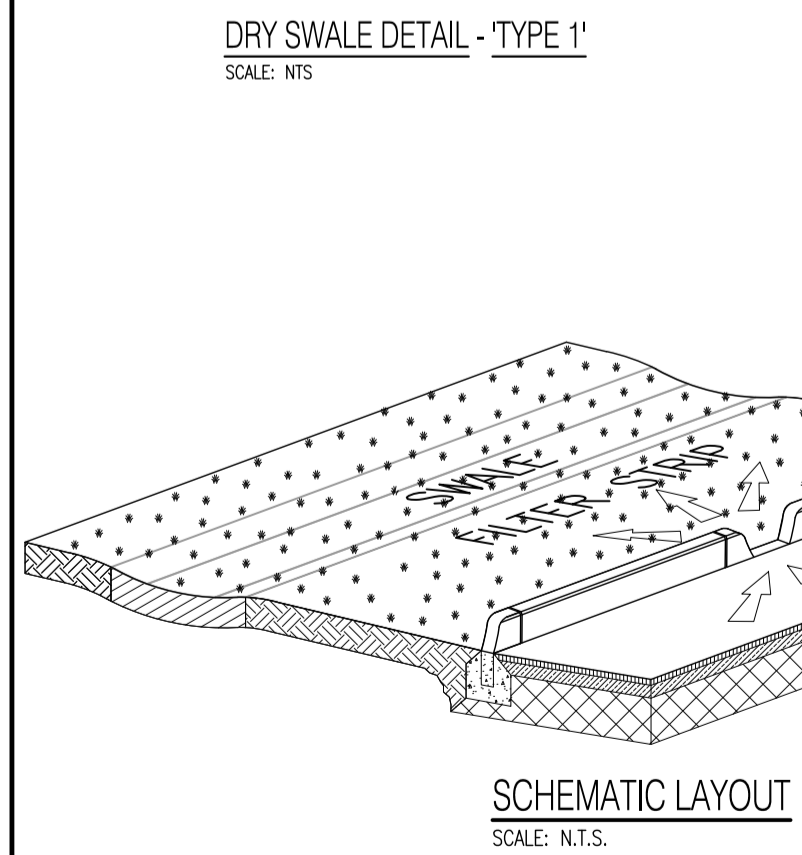
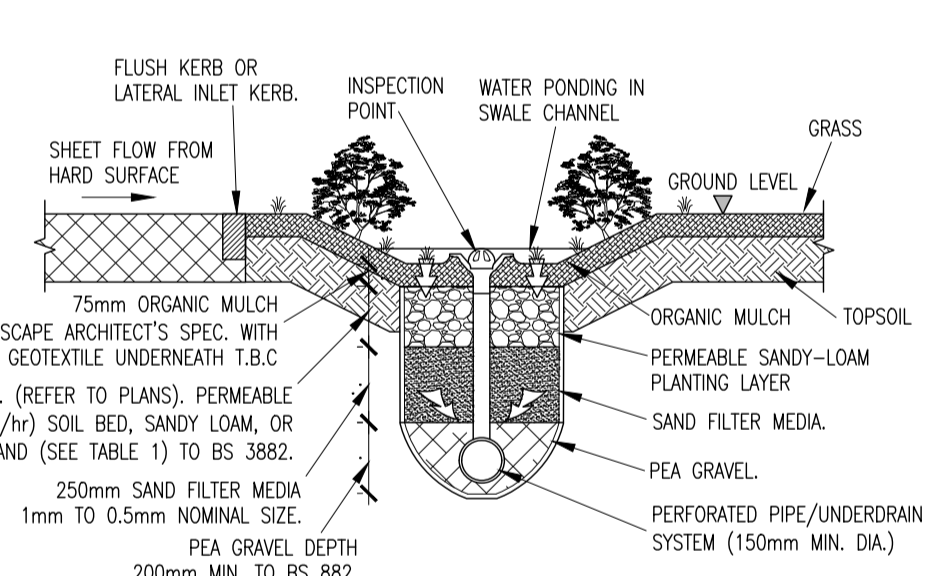
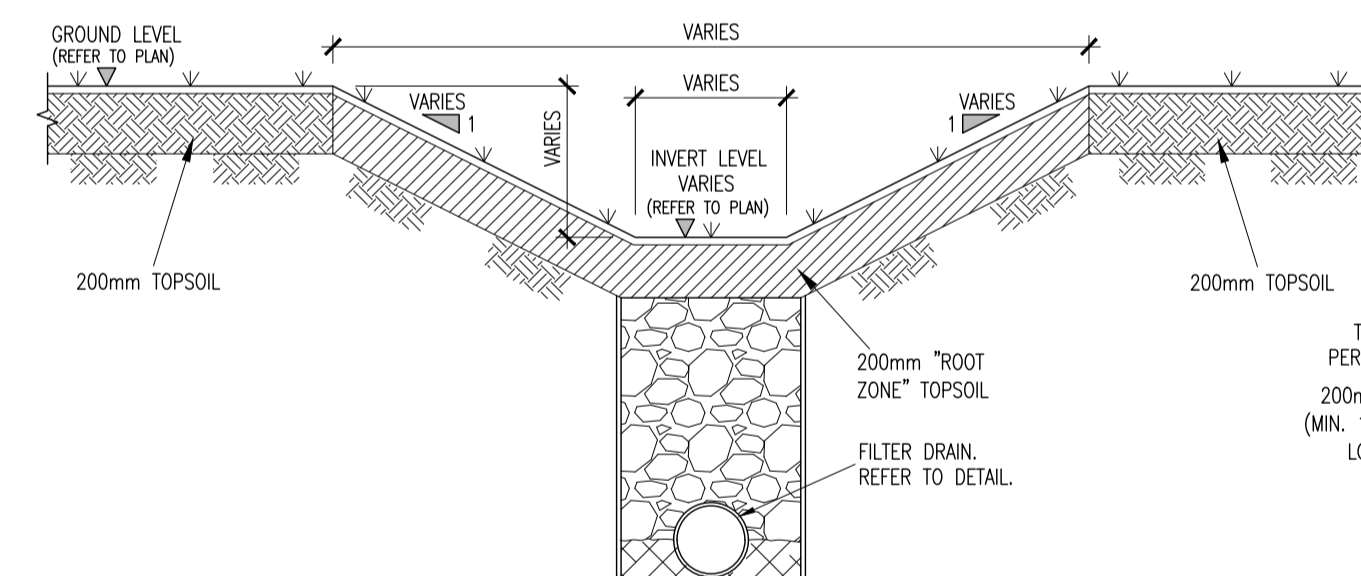
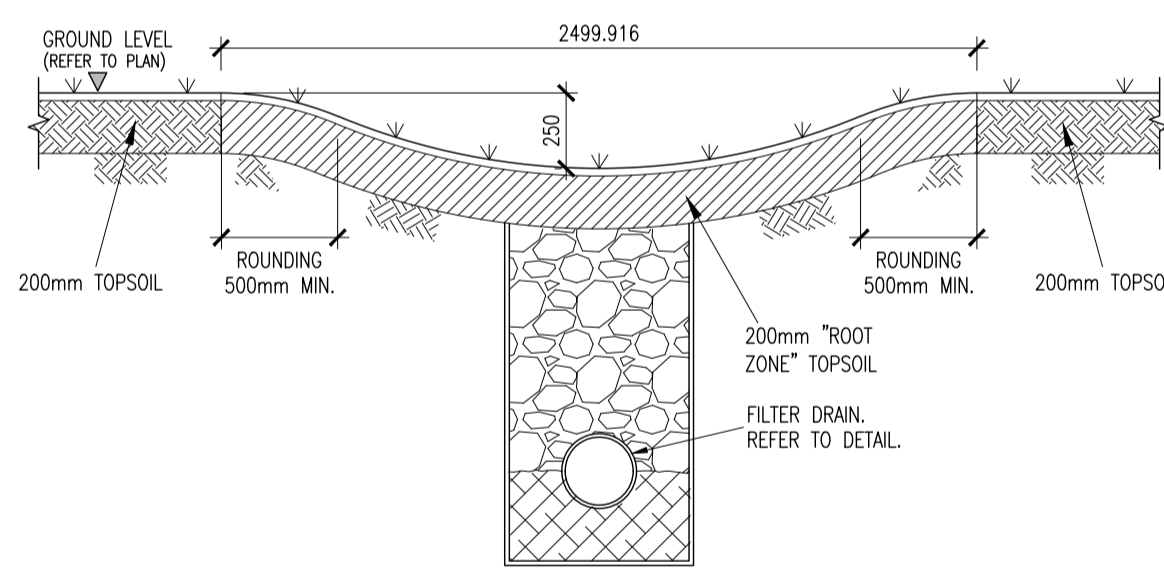
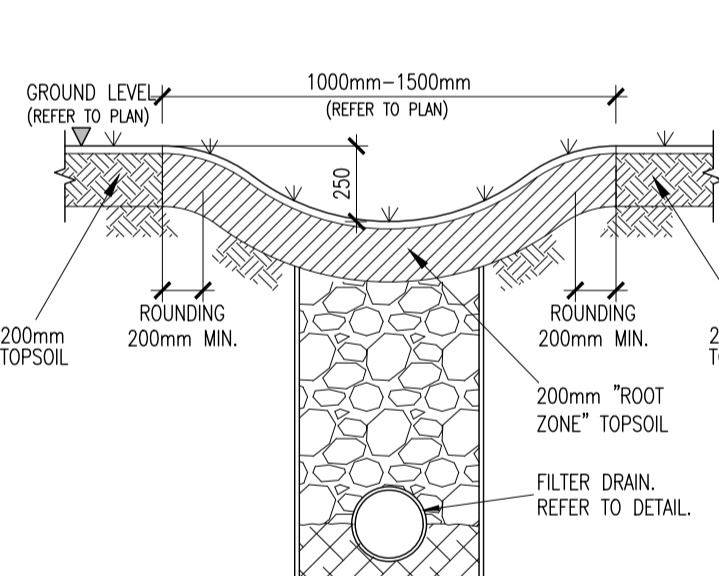
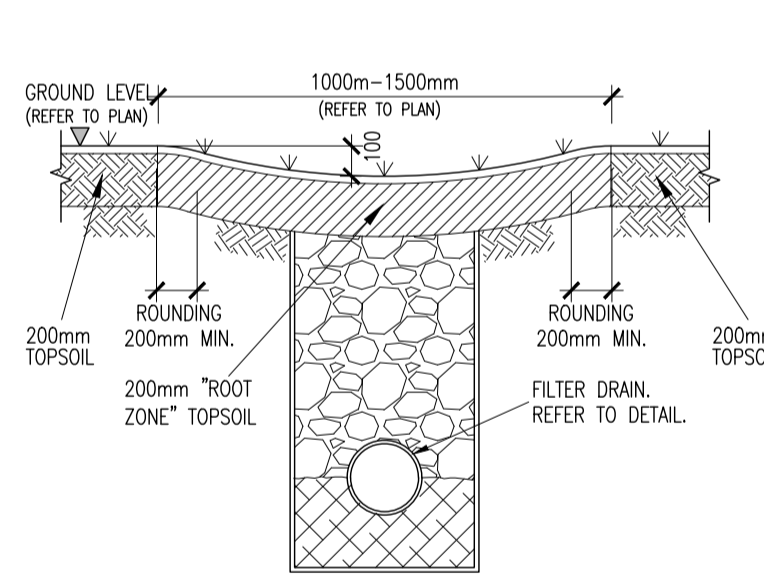

TABLE 1

COMPONENT	PERCENTAGE MIXTURE
SAND	35-60%
SILT	30-50%
CLAY	10-25%
ORGANIC MATTER	0-4%
TOP SOIL	-



ON-LINE BIORETENTION AREA - SCHEMATIC LAYOUT
SCALE: N.T.S.



TYPICAL ROADSIDE LATERAL KERB INLET (NON-CONTINUOUS KERB)

TYPICAL ROADSIDE LATERAL KERB INLET (KERB WITH PIPE OUTLETS)

© COPYRIGHT OF THIS DRAWING IS RESERVED BY DBFL CONSULTING ENGINEERS. NO PART SHALL BE REPRODUCED OR TRANSMITTED WITHOUT THEIR WRITTEN PERMISSION.

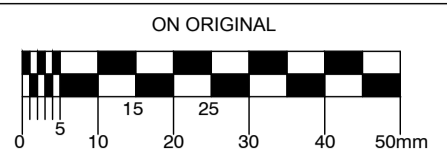

- NOTES:**
- ALL WORKS TO BE CONSTRUCTED IN ACCORDANCE WITH NRA SPECIFICATION FOR ROADWORKS UNLESS OVERRIDDEN BY GREATER DUBLIN REGIONAL CODES OF PRACTICE FOR DRAINAGE WORKS AS AMENDED BY DUBLIN CITY COUNCIL.
 - ALL DRAWINGS TO BE CHECKED BY CONTRACTOR ON SITE AND ENGINEER INFORMED OF DISCREPANCIES BEFORE WORK COMMENCES.
 - ALL LEVELS ARE IN METRES AND ARE RELATED TO THE ORDINANCE DATUM.
 - CONTRACTOR SHALL SATISFY HIMSELF AS TO THE ACCURACY OF PAVEMENT LEVELS ON SITE PRIOR TO COMMENCEMENT OF WORKS.

REV	DATE	DESCRIPTION	BY	CHKD
PLANNING				
DESIGNED	NGC	PREPARED	PJC	
DATE	SEP 2019	CHECKED	DJR	

DBFL

Dublin Office: Ormrod House, Upper Ormrod Quay, Dublin 7, Ireland. PHONE +353 1 400 4000 FAX +353 1 400 4050

Waterford Office: Unit 2, The Chandlery, 1-2 O'Connell Street, Waterford, Ireland. PHONE +353 51 308 500 FAX +353 51 844 913

DBFL Consulting Engineers email: info@dbfl.ie site: www.dbfl.ie

PROJECT
LANDS AT NEWCASTLE, SOUTH DUBLIN

DRG. TITLE
TYPICAL SW DRAINAGE DETAILS SHEET 3

ARCHITECT
MOLA

SCALE	N.T.S. @A1	FILE REF.	170024-3015
DRG. NO.	170024-3017		